

MODELS 5D011, 5D011W,
5D011Y, 5D027, Ch. 5C01
5D011Z, 5D011ZW, 5D011ZY,
5D027Z, Early, Late
Chassis 5C01Z

ZENITH RADIO CORP.

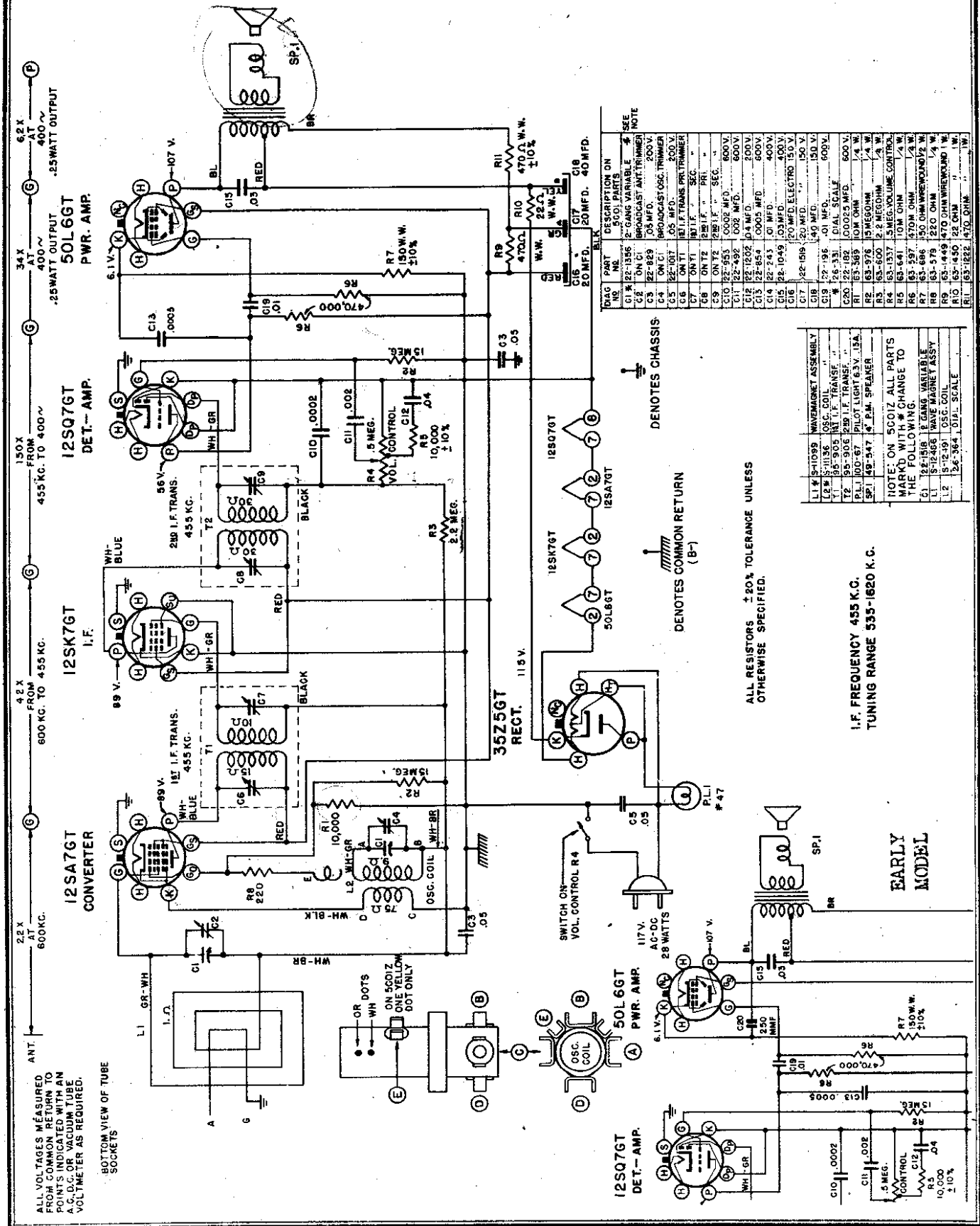

ZENITH RADIO CORP.

MODELS 5D011 Series,
5D011Z Series
MODELS 5R080, 5R086

TO THE SERVICE MAN:

The filter circuits of chassis 5C01 incorporate new features that should be well understood by the service man. An examination of the schematic drawing will show the output transformer tapped slightly off center. This tap is the B+ connection from filter resistor R10 and capacitor C18 off the cathode of the rectifier 35Z5 to the 50L6 plate. The lower connection of the output transformer feeds B+ to the rest of the tubes in the receiver. Current flowing through the upper windings of the output transformer to the 50L6 produces a magnetic field which is 180° out of phase with the magnetic field produced by current flowing in the opposite direction through the output transformer to the rest of the receiver, therefore, most of the AC hum is cancelled. Further reduction of hum is accomplished by filtering through resistor R9 and 11 and capacitors C16 and 17. Capacitor C15 across the primary of the output transformer by passes high frequency back to ground.

This development in filtering systems allows a higher effective plate voltage on the 50L6 for increased power output.

NOTE: The output transformer must be replaced with an exact duplicate Part No. 202-549. Be sure to add the speaker code letter to the transformer Part number.

MODELS 5D011-5D027

CHASSIS No. 5C01

ALIGNMENT PROCEDURE

OPERATION	CONNECT OSCILLATOR TO	DUMMY ANTENNA	INPUT SIG. FREQUENCY	SET DIAL AT	TRIMMERS	PURPOSE
1	Converter Grid	.5 Mfd.	455 Kc.	600 Kc.	C-6, C-7, C-8, C-9	Align I. F. Set Oscillator to Dial Scale.
2	One Turn Loop Coupled Loosely to Wave Magnet	--	1600 Kc.	1600 Kc.	C-4	Align Antenna Stage
3		--	1400 Kc.	1400 Kc.	C-2	

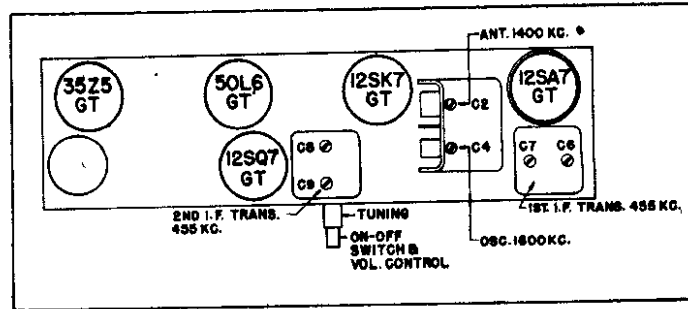

TUBE AND TRIMMER LOCATION

TO THE SERVICE MAN:

The 5C02 and 5C04 chassis are identical electrically. Chassis 5C02 has a Record Reject push button switch on the receiver control panel to reject records.

The socket P1 is used to connect the automatic record changer to the receiver.

The Phono-Radio switch is a two position double acting push-button switch and when in the "in" position connects the changer for playing records.

Chassis 5C04 has the same Phono-Radio switch arrangement. However, the 5C04 does not have socket P1 and the Record Reject switch. The record player is connected to the receiver by a shielded cable and socket arrangement.

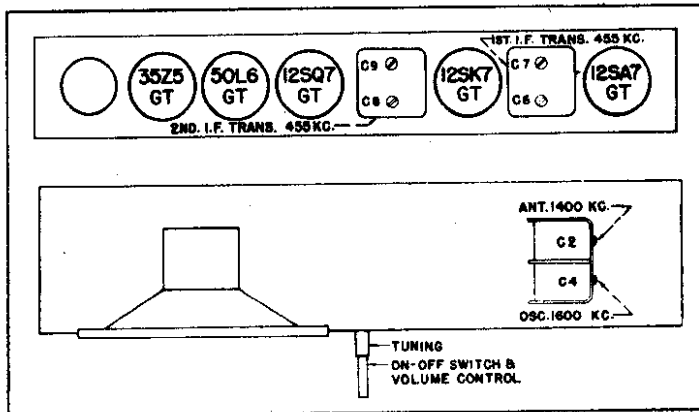

TUBE AND TRIMMER LOCATION

MODELS 5R080-5R086

CHASSIS Nos. 5C02-5C04

ALIGNMENT PROCEDURE

OPERATION	CONNECT OSCILLATOR TO	DUMMY ANTENNA	INPUT SIG. FREQUENCY	SET DIAL AT	TRIMMERS	PURPOSE
1	Converter Grid	.5 Mfd.	455 Kc.	600 KC.	C-6, C-7, C-8, C-9	Align I. F. Set Oscillator to Dial Scale.
2	Single Turn Loop Loosely Coupled to Wave magnet		1600 Kc.	1600 Kc.	C-4	
3			1400 Kc.	1400 Kc.	C-2	Align Ant