

USE ONLY ZENITH NON-INDUCTIVE ELECTROLYTIC CONDENSERS FOR REPLACEMENT. IF ANY OTHER TYPE OF ELECTROLYTIC IS USED, IT WILL BE NECESSARY TO ADD PARTS SHOWN IN DOTTED LINES.

I.F. FREQUENCY 455 KC.

TUNING RANGE
535 — 1620 K.C.

ALL VOLTAGES MEASURED FROM COMMON RETURN TO POINTS INDICATED WITH A A.C., D.C. OR VACUUM TUBE VOLTMETER. ALL VOLTAGES ARE D.C. UNLESS OTHERWISE SPECIFIED. ALL RESISTORS ARE ±20% TOLERANCE UNLESS OTHERWISE SPECIFIED.

⊕ DENOTES CHASSIS
⊕ DENOTES COMMON RETURN

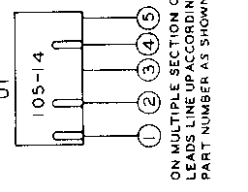

ON MULTIPLE SECTION CAPACITORS LEADS LINE UPACCORDING TO THE PART NUMBER AS SHOWN.

PARTS LIST

PART NO.	DESCRIPTION	QTY	REMARKS
DIAL ASSEMBLY			
26-414	Dial Scale	1	
57-222	Dial Pointer	1	
76-235	Tuning Shaft	1	
86-200	Push Light Socket & Wire	1	
100-657	Dial Cord Tension Spring	1	
188-32	Dial Light Bulb - 6.3V. -15 Amp.	1	
188-54	Retaining Ring (Pointer)	1	
514843	Dial Cord & Eyelet Assem.	1	
COILS & CHOKES			
95-1101	1st I.F. Transformer	1	
95-1102	2nd I.F. Transformer	1	
514842	Osc. Coil Assem.	1	
CONDENSERS			
C-14	100 Mmfd. (or 22-1669)	1	500V.
C-4	.05 MFD.	1	200V.
C-11	.0005 Mfd.	1	600V.
C-13	.05 MFD.	1	200V.
C-5	.02 MFD.	1	400V.
C-15, 16	.047 Mfd.	2	400V.
C-1	22-1804	1	150V.
C-1	Two Section Gang	1	
U-1	Dual Ceramic	1	
RESISTORS			
R-9	150 Ohm W.W. Insul.	1	1/2W
R-11	22 Ohm W.W. Insul.	1	1/2W
R-10	10000 Ohm. Insul.	1	1W
R-4	Vol. Con. & Sw.	1	
R-2	88 Ohm Insul.	1	1/2W
R-5	920 Ohm Insul.	1	1/2W
R-6	4700 Ohm Insul.	1	1/2W
R-11	50M Ohm Insul.	1	1/2W
R-8	40M Ohm Insul.	1	1/2W
R-3	2.2 Megohm Insul.	1	1/2W
R-7	4.7 Megohm Insul.	1	1/2W
MISCELLANEOUS			
11-79	Line Cord & Plug (6 Ft.)	1	
14-1011	Model 811 Plastic Cabinet	1	
14-1011W	Model 811W Plastic Cabinet	1	
14-1011Y	Model 811Y Plastic Cabinet	1	
43-165	Handle Housing	1	
46-744	Tuning & Vol. Con. Knob (2 Used) (5D811)	2	
46-744Y	Tuning & Vol. Con. Knob (2 Used) (5D811W - 811Y)	2	
49-645	4" P.M. Speaker	1	
54-211	206-645 Output Trans.	1	
57-1408	208-645 Cone & Voice Coil	1	
78-275	Speed Nut	1	
78-511	Cabinet Front Plate	1	
78-806	Socket - Electrolytic	1	
78-807	Socket - Octal Tube (8 Contact)	1	
83-1057	Socket - Miniature Tube	1	
83-1393	Socket - Miniature Tube	1	
93-487	Line Cord Insulating Strip	1	
94-334	Rubber Strip (Handle)	1	
102-543	1/16 x .144 x 3/8 Steel Washer	1	
112-607	Gang Cond. Mig. Bushing	1	
112-697	Insignia Label	1	
114-67	#6 x 3/8 R.H.S.T. Screw	1	
114-217	#6-32 x 7/16 Hex Acorn Hd. M.S. (3 Used)	3	
125-17	#8 x 1/4 Hex Hd. Slotted S. T. Screw (2 Used)	2	
139-74	Rubber Grommet	1	
159-69	Spk. Baffle	1	
166-44	Trimount Stud (Cab. Back Mfg.)	1	
199-103	Rubber Bumper (or 166-41)	1	
202-665	Flexible Handle Sleeve (5D811)	1	
512410	Instruction Book	1	
514952	Strip & Ret. Assem. (Handle Strip)	1	
514976	Front Plate & Spk. Baffle Assem.	1	
514977	Wave magnet Assem. (5D811-811Y)	1	
514977	Wave magnet Assem. (5D811W)	1	

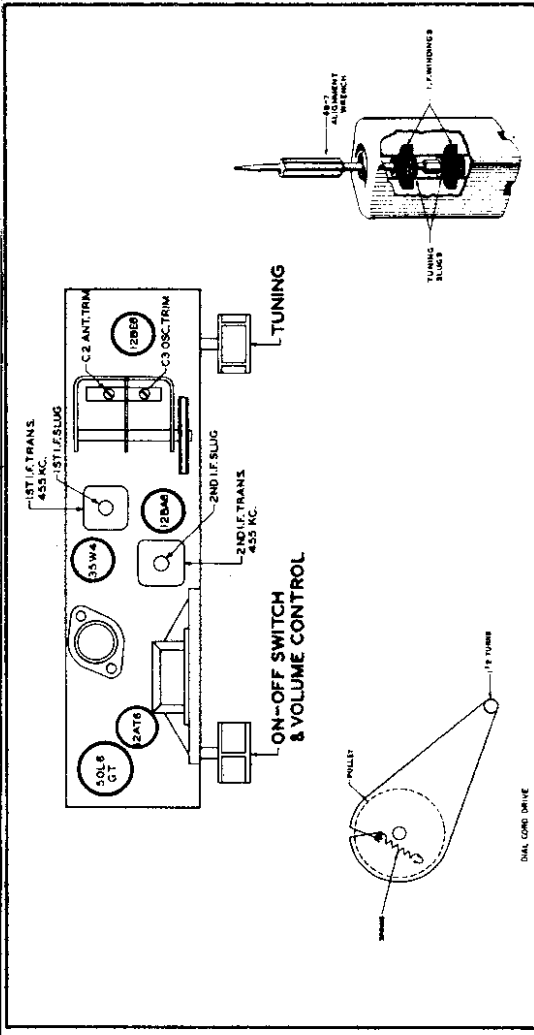

TUBE, TRIMMER LOCATION, DIAL CABLE DRAWING AND DETAILED VIEW OF I. F. TRANSFORMERS.

The I.F. transformers incorporated in this receiver are of the new permeability tuned type. The advantage of an I. F. transformer of this type is its extreme stability under various humidity and temperature conditions. The upper coil is the secondary and the lower the primary. When adjusting these I. F. transformers the tuning wrench 68-7 can be inserted into the top slug, rotated until maximum output is obtained and then dropped down to the lower slug and the same operation repeated. The tuning wrench is so designed that turning one slug does not affect the adjustment of the other.

ALIGNMENT PROCEDURE

OPERATION	CONNECT OSCILLATOR TO ANTENNA	DUMMY ANTENNA	INPUT SIG. FREQUENCY	SET DIAL AT	TRIMMERS	PURPOSE
1	Converter Grid	.5 Mfd.	455 Kc.	600 Kc.	Adjust Primary & Secondary Slugs	For I. F. Alignment
2	One Turn Loop Coupled Loosely to Wave Magnet	--	1600 Kc.	1600 Kc.	C-3	Set Oscillator to Dial Scale.
3		--	1400 Kc.	1400 Kc.	C-2	Align Antenna Stage

Westinghouse H-203, H-212

These models appear on pages 19-29 through 19-32 of *Rider's Manual Volume XIX*. The volume control is tapped at 50,000 ohms from ground rather than 450,000 ohms as shown on the schematic diagram.

In later production, a 33-ohm, 1/4-watt resistor (RC10AE330K) was inserted in the lead from pin 7 of the 6BE6 oscillator-converter tube. The purpose of this resistor is to suppress parasitic oscillations that may develop when certain 6BE6 tubes are used.

In early sets, R35 in the cathode circuit of the 12AT7 FM r-f amplifier and mixer tube served as a form around which was wound the reactor, L21. For convenience in later production, the resistor was deleted from the circuit and the reactor was wound on other material. The part number, V-4886-10, shown in the parts list for this item applies to the later version which does not include the resistor, and R35 should be disregarded.

On some chassis, V-5596 "HI-KAP" capacitors are substituted for V-5040-13, C36 and C37, capacitors. These capacitors were substituted for convenience in production, and the operation of the receiver is not affected by the substitution.

Zenith 8H832, Ch. 8E20

This chassis appears on pages 19-16 through 19-21 of *Rider's Manual Volume XIX*. If replacement of one of the speakers is required, care should be taken when connecting the new speaker in the circuit so that the speakers are properly phased. If the speakers are out of phase, all bass notes will be absent and distortion will be dominant. This condition can be corrected by reversing the voice coil wires on the newly replaced speaker.

Zenith 7H820Z, Ch. 7E01Z

Chassis 7E01Z is similar to Chassis 7E01 except that the 45-megacycle f-m band has been removed. The receiver now has the broadcast band and the 100-megacycle i-m band only. The new section is shown in the accompanying diagram. Balancing procedure is the same as for the 7E01.

The change in Parts List is given below:

Ref. No.	Part No.	Description
C30	22-1775	0.047 μ f, 400 v
C10	22-1778	0.047 μ f, 200 v
C19	22-1809	0.01 μ f, 200 v
C25	22-1810	0.1 μ f, 200 v
C24	22-1811	0.0047 μ f, 400 v
C22	22-1813	0.22 μ f, 600 v
C15	22-1814	0.0022 μ f, 600 v
	58-128	Two-prong plug
	74-52	Plastic speaker screen
	83-1545	Insulating strip
	85-443	Bandswitch
	93-690	Felt washer
	93-719	0.031 x 3/16" x 7/16" steel washer
	93-961	Ins. shoulder washer
	114-160	6 x 7/8" hex. hd. s.t. screw
	114-277	8-32 x 9/16" hex. hd. m.s.

Zenith 5D811, Ch. 5E01

Model 5D811, Ch. 5E01, was erroneously listed in the Volume XX Index as 5D811, Ch. 5F01.

Zenith 5G003Z, Ch. 5C40Z

This model appears on page 16-4 of *Rider's Manual Volume XVI*, R2 is listed as 2,200 ohms. It should be listed as 220 ohms.

Zenith 7H820, Ch. 7E01

On some of the later run 7E01 chassis, the wax bypass capacitors were replaced with molded capacitors. Their part numbers are as follows:

Ref. No.	Part No.	Description
C10	22-1778	Capacitor, 0.047 μ f, 200 v, molded
C22	22-1750	Capacitor, 0.022 μ f, 600 v, molded
C15	22-1754	Capacitor, 0.0022 μ f, 600 v, molded
C19	22-1809	Capacitor, 0.01 μ f, 200 v, molded
C24	22-1811	Capacitor, 0.0047 μ f, 400 v, molded
C25	22-1810	Capacitor, 0.1 μ f, 200 v, molded.

Zenith 7H822Z, Ch. 7E02Z

Chassis 7E02Z is similar to the 7E02 which appears on pages 18-21,22 through 18-25 of *Rider's Manual Volume XVIII*. On the 7E02Z receiver a tone control has been added and a neon bulb on-off indicator. The accompanying figure shows the tone-control circuit. The following parts list shows the new components included in this receiver:

Part No.	Description
12-1546	Indicator socket brkt.
14-857	Model 822Z plastic cab.
22-1025	0.15 μ f, 200 v, capacitor
22-1511	50 μ f, ceramic 500 v, capacitor
26-419	Dial scale
46-769	Tuning & vol. con. knob
46-770	Band-switch knob
46-780	Tone-control knob
46-781	Tone-control knob
63-1744	100 ohms, ins. resistor, 20%, 1/2 w
63-1884	220,000 ohms, ins. resistor, 20%, 1/2 w
63-2008	Tone control
78-585	Indicator socket
80-402	Dial cord tension spring
83-1593	Felt strip (2 used)
83-1595	Spacer strip
93-961	Ins. shoulder washer
100-105	Neon indicator bulb
199-35	Dial scale
202-687	Instruction book
S-15325	Cab. back & plug cover assy.

The 220,000-ohm resistor, R22, and the neon bulb on-off indicator have been inserted from pin 4 of the 35B5 power amplifier to ground.

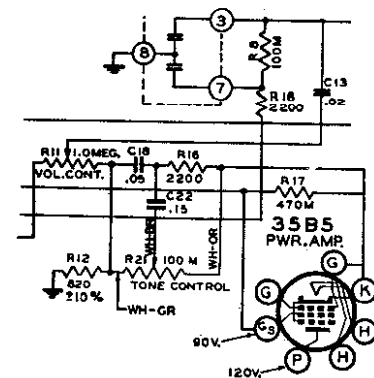

Circuit changes for the Zenith 7H822Z, Chassis 7E02Z.

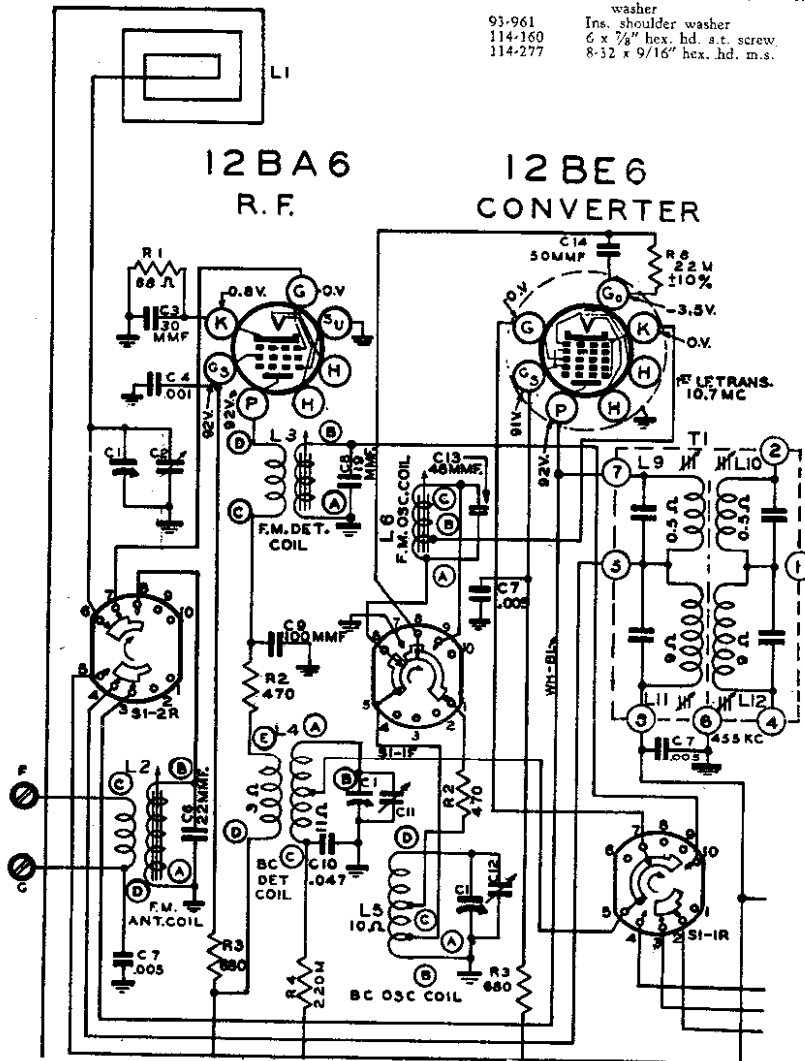

Partial Schematic for Zenith 7H820Z, showing elimination of 45Mc FM Band.