

ZENITH RADIO CORP

MODEL 5M191
Chassis 5520
Schematic, Voltage
Changes, Parts

I.F. FREQUENCY 456 K.C.

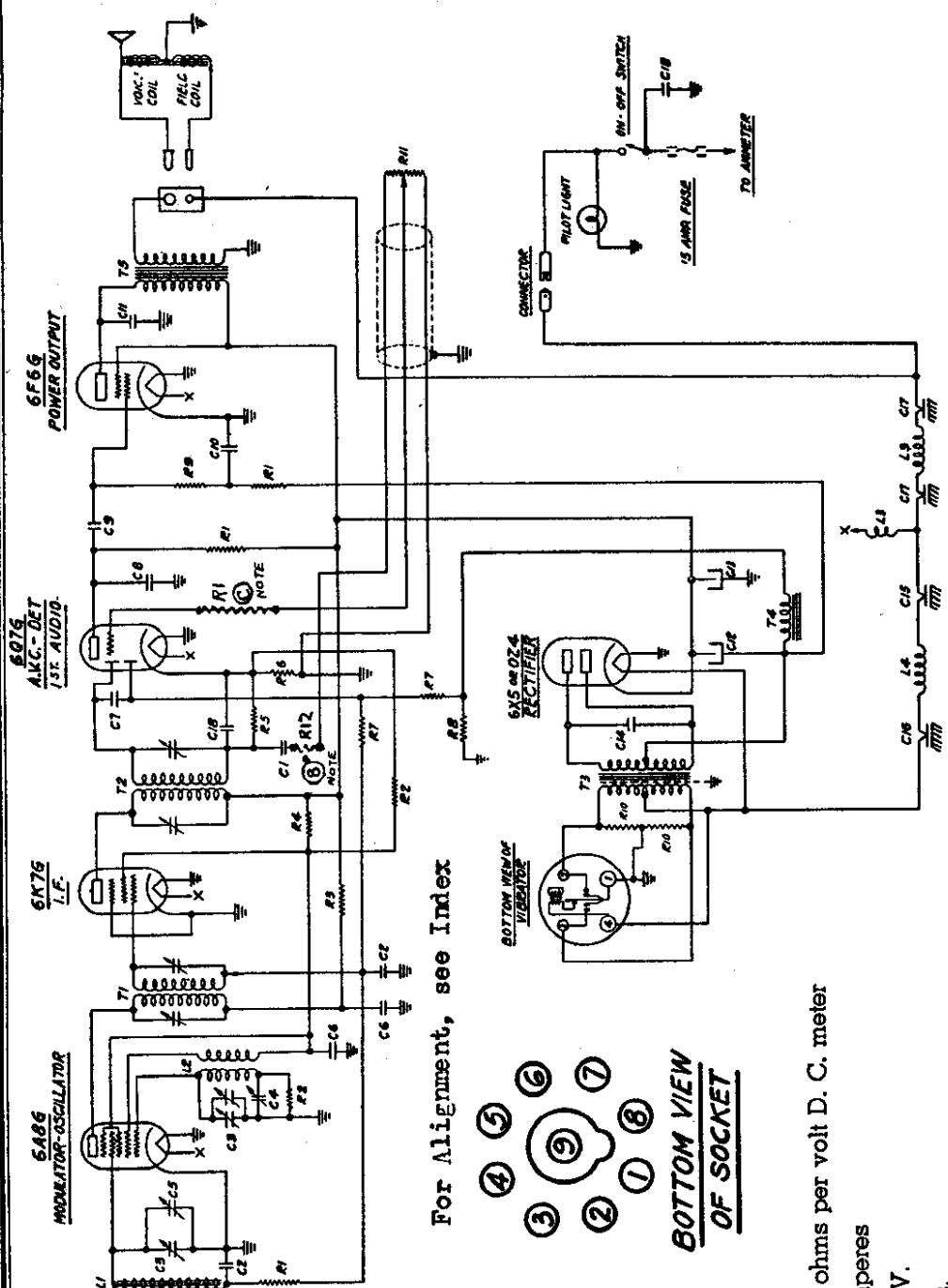
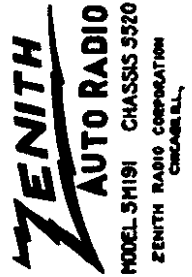

For Alignment, see Index

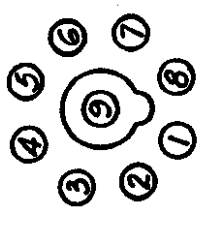

BOTTOM VIEW OF SOCKET

Voltage at Battery 6V.

Voltage at Receiver 5.9 V.

Antenna disconnected

All voltages measured with 1000 ohms per volt D. C. meter

Total current consumption 5.5 amperes

Sensitivity at 1 watt out put 5 M. V.

Maximum power output 3.2 watts.

SOCKET VOLTAGES MODEL 5M-191

| Tube | Position | 1 | 2 | 3 | 4 | 5 | 6 | 7 | 8 | 9 |
|------|---------------------|---|---|-----|--------------|------|----|-----|----|---|
| 6A8 | Mixer Osc. | 0 | 0 | 190 | 90 | -4 | 90 | 5.9 | 0 | 0 |
| 6K7 | I. F. | 0 | 0 | 195 | 90 | 0 | - | 5.9 | 0 | 0 |
| 6Q7 | Det. A. V. C. Audio | 0 | 0 | 80 | 0 | -1 | - | 5.9 | .8 | 0 |
| 6F6 | Power | 0 | 0 | 185 | 195 | -3.5 | - | 5.9 | 0 | - |
| OZ4 | Rectifier | | | | Inaccessible | | | | | |

MODEL 5M191
 Socket, Trimmers
 Chassis, Drive Data

ZENITH RADIO CORP.

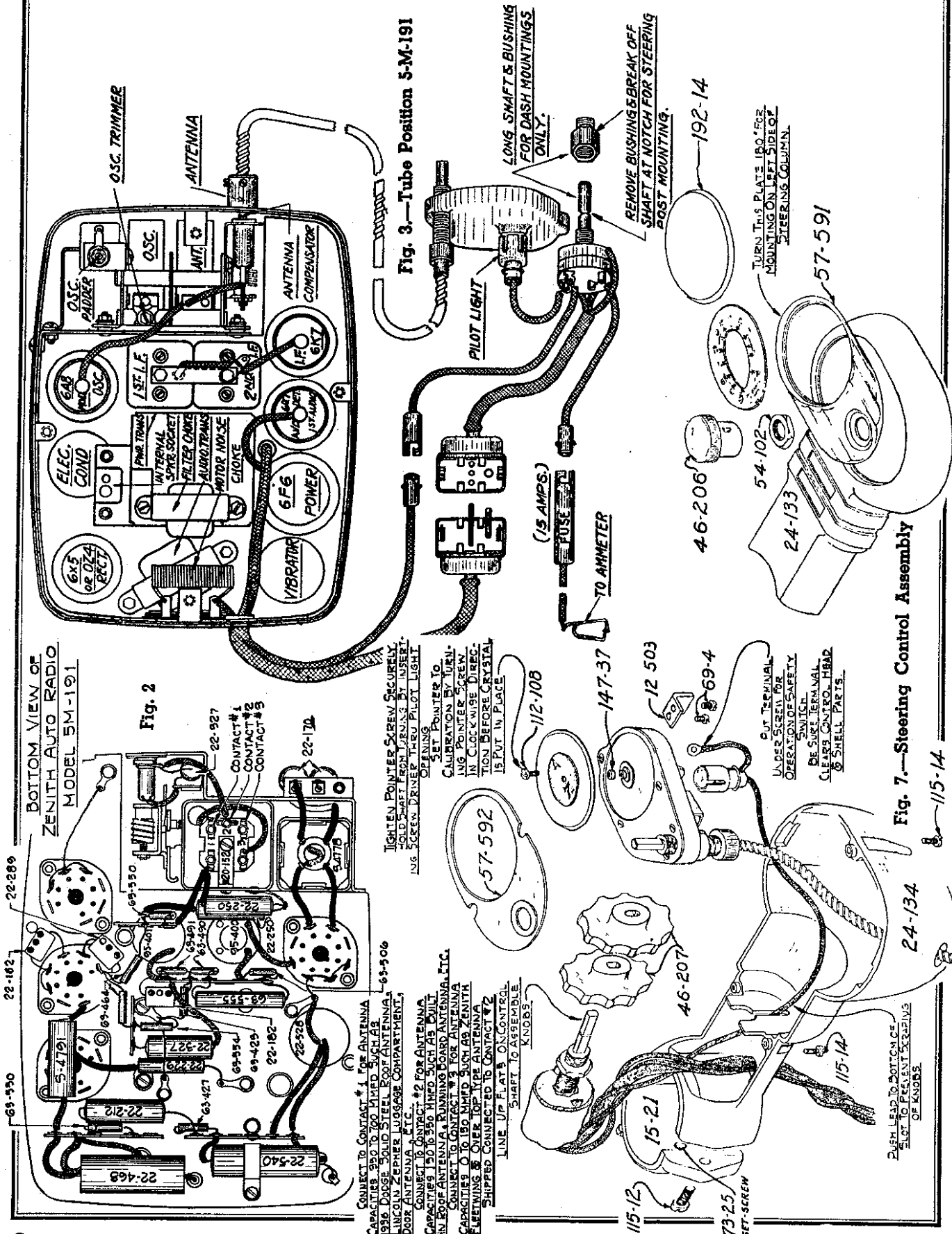

©John F. Rider, Publisher

ZENITH RADIO CORP.

MODEL 5M191
 MODELS 6M192, 6M193, 6M194
 MODEL 8M195
 Alignment, Notes

IMPORTANT ANTENNA INFORMATION (All Models)

Some cars are factory equipped with an antenna. If this is the case, the lead should be checked to make certain that it is not grounded, and after being shielded by a large diameter loom, ground this loom to the instrument panel, and attach the Delco-Remy male connector to the end of the antenna wire. This should be done carefully, so as to insure a good solder joint, and prevent any grounding at this point to the braided shielding. Insert the antenna lead-in connector into the female Delco-Remy receptacle directly below the tuning cable shoulder on the receiver case.

Where a car is not equipped with an antenna, such as convertible models, or those with all steel turret top, any one of the following Zenith antennas may be used:

- Undercar antenna—part No. S-4800 and S-4801.
- Over the Top Antenna (Sedan) S-4802.
- Over the Top Antenna (Coupe) S-4803.
- Zenith Fleet Wing Antenna S-4821.
- Zenith Bumper Pole Antenna S-4822.

Complete instructions covering the installation of each of the above antennas is furnished with the various kits.

IMPORTANT: BALANCING SET TO ANTENNA. There is such an extremely wide variation in antenna capacities that it is difficult to match this condition without some means of variable antenna alignment. To accomplish this, an antenna compensating adjustment is provided through the small hole directly above the antenna cable connector on the receiver case. In addition to this, a tapped antenna transformer is also incorporated (see Figure No. 2). The proper method of alignment is as follows: After completely connecting receiver, tune in a signal between 1400 and 1450 K.C. and adjust the antenna compensator shown in Figure 3, for either the roof antenna, or single or double undercar antenna. The receiver is shipped from the factory with the antenna top shown in Figure 2 set to the No. 2 position, and, therefore, need not be changed for either of the two types of antennas mentioned.

For Zenith Fleet Wing, and Over the Top Antennas, unsolder the antenna lead from the No. 2 lug, and resolder it to the No. 3 lug. After this is done, tune in a station between 1450 and 1400 K.C., and adjust the antenna compensator shown in Figure 3 to resonance.

For high capacity antennas such as the 1936 Dodge solid steel roof, or the Lincoln Zephyr luggage compartment, driver's antenna, etc., remove the antenna lead from the No. 2 lug, as it comes from the factory, and resolder it to the No. 1 connector. After this is done, the same procedure of tuning in a signal from 1450 to 1400 K.C., and balancing to resonance with the antenna compensator, as described above, should be followed.

This system of tapped transformer, and variable compensating adjustment gives an extremely flexible means of resonating the receiver to any type of antenna, and it should be noted that the tap need only be changed in two cases. Of course, it is necessary to remove the bottom cover in order to shift the antenna top where necessary.

IGNITION INTERFERENCE

Remove the center high tension lead of the distributor and insert the suppressor into the distributor at that point. The wire is then placed in the open end of the suppressor. The generator condenser is fastened under the cut-out housing and the wire connected to the generator connection on the cut-out. The coil condenser is attached to the battery connection of the coil and the other end to the coil case. Make absolutely certain that this condenser is not accidentally connected to the distributor side of the coil since this will increase motor noise terrifically and make operation of the receiver highly unsatisfactory when the motor is running. Where two distributors or two coils are employed a corresponding number of condensers and suppressors must be applied. In some instances it might be of benefit to attach a by-pass condenser from one side of the armature to a grounded part of the instrument panel. If the dome light is feeding interference to the antenna the lead should be cut where it comes from the post and a switch inserted on the instrument panel at that point, to turn it off and on. In some cases, a by-pass condenser connected to the dome-light lead and grounded at the post is as effective as a separate switch. Try this first.

If additional attention is necessary to reduce motor interference, the motor block must be securely bonded, both at the rear and front supports with $\frac{1}{2}$ inch copper braid. Also bond or ground all metal control cables or pipes feeding from the motor side into the car. These bonds should be made to the control wire or pipe and soldered to the fire wall immediately adjacent on the motor side. As a further precaution the rotor should be lengthened to reduce the gap between it and the distributor head contacts by either peening the end or applying a small quantity of solder at this point.

ALIGNMENT

5-M-81

"A" Connect the service oscillator output leads to the control grid of the 6A8 tube, and to the chassis. If the oscillator output is a single shielded lead the shield should connect to the chassis.

Connect an output meter across the primary of the speaker transformer.

Set the service oscillator at 455 K.C. and adjust the trimmers on the I.F. transformers to the point giving the greatest reading on the output meter. These, as well as the following adjustments should be made using as small an output from the signal generator as possible so that the A.V.C. action will be least effective.

"B" Change the service oscillator lead from the grid of the 6A8 to the antenna connection. A male Delco Remy connector may be used in making a connection to the antenna lead.

Set the service oscillator at 1600 K.C. and rotate the gang condenser until the plates are entirely out of mesh. Adjust the oscillator section trimmer until the 1600 K.C. signal is tuned in.

"C" Set the service oscillator to 600 K.C. and rock the gang condenser slowly to and fro past the point where this signal is received, meanwhile adjusting the paddler condenser for a setting which gives the greatest output reading.

"D" Repeat operation "B". See antenna instruction page 373 for correct alignment of antenna stage.

6-M-192 — 6-M-193 — 6-M-194 — 8-M-195

"A" Connect the service oscillator to the control grid of the 6A8 tube and the chassis.

Connect the output meter across the primary of the speaker transformer.

Set the service oscillator to 252.5 K.C. and adjust the trimmers on the I.F. transformers for the greatest output reading. These adjustments should be repeated several times using as weak an input signal as possible so as to obtain greater accuracy.

"B" Change the service oscillator lead from the grid of the 6A8 to the antenna connection. A male Delco Remy connector may be used in making a connection to the antenna lead.

Set the service oscillator at 1600 K.C. and rotate the gang condenser until the plates are entirely out of mesh. Adjust the oscillator section trimmer until the 1600 K.C. signal is tuned in.

Change the service oscillator to 1400 K.C. Rotate the gang condenser until this signal is tuned in, and then adjust the R.F. trimmer on the gang condenser to the point giving the greatest output reading.

"C" Set the service oscillator to 600 K.C. and rock the gang condenser slowly to and fro past the point where this signal is received, meanwhile adjusting the paddler condenser for a setting which gives the greatest output reading.

"D" Repeat operation "B".

The sensitivity control should be in the extreme clockwise position when making all adjustments.

NOTE — Due to the high gain type of I.F. transformers used in these receivers it is essential that a non-metallic screw driver be used in making all adjustments. See antenna instructions for correct alignment of antenna stage.

SERVICE NOTE

The OZ4 rectifier tube used in the 5 and 6 tube models may be replaced with a 6X5 rectifier, providing the 6X5 tube is enclosed in a grounded tube shield.

The Gear shield with a "grow" clip which connects to the shield contact pin of the tube is the most convenient type to use.

MODEL 5M191
 MODEL 5 6M192, 6M193, 6M194
 MODEL 8M195
 Parts Lists

ZENITH RADIO CORP.

| Part No. | Description | QTY | ST. PRICE |
|----------|----------------------------------|-----|-----------|
| 5290 | Antenna Cable - Ammeter End | .50 | .25 |
| 54102 | 3/8-32 x 1/2" Hex Nuts Cordanium | .25 | .25 |
| 57478 | Set Mounting Plate | .25 | .25 |
| 58-25 | Delco-Remy Fuse Bushing | .01 | .01 |
| 63-336 | 15 M. ohm Distributor Suppressor | .35 | .35 |
| 69-84 | No. 10/32 x 1/4" R.H.M.S. | .30 | .30 |
| 93-127 | No. 10 Mounting Strap | .35 | .35 |
| 93-143 | Lockwasher | .01 | .01 |
| 93-222 | 7/16" Internal Shakerproof | .01 | .01 |
| 93-233 | Lockwasher | .01 | .01 |
| 138-5 | 2 1/4" Dia. | .02 | .02 |
| 158-4 | 15 M. ohm Fuse | .02 | .02 |
| 183-2 | 7/16" x 3/8" Locking Bolt & Nut | .01 | .01 |
| 186-1 | Insulation Template | .01 | .01 |
| 186-1 | Mounting Plate Gasket | .03 | .03 |

| Part No. | Description | QTY | ST. PRICE |
|----------|----------------------------------|-----|-----------|
| 5290 | Antenna Cable - Ammeter End | .50 | .25 |
| 54102 | 3/8-32 x 1/2" Hex Nuts Cordanium | .25 | .25 |
| 57478 | Set Mounting Plate | .25 | .25 |
| 58-25 | Delco-Remy Fuse Bushing | .01 | .01 |
| 63-336 | 15 M. ohm Distributor Suppressor | .35 | .35 |
| 69-84 | No. 10/32 x 1/4" R.H.M.S. | .30 | .30 |
| 93-127 | No. 10 Mounting Strap | .35 | .35 |
| 93-143 | Lockwasher | .01 | .01 |
| 93-222 | 7/16" Internal Shakerproof | .01 | .01 |
| 93-233 | Lockwasher | .01 | .01 |
| 138-5 | 2 1/4" Dia. | .02 | .02 |
| 158-4 | 15 M. ohm Fuse | .02 | .02 |
| 183-2 | 7/16" x 3/8" Locking Bolt & Nut | .01 | .01 |
| 186-1 | Insulation Template | .01 | .01 |
| 186-1 | Mounting Plate Gasket | .03 | .03 |

| Part No. | Description | QTY | ST. PRICE |
|----------|----------------------------------|-----|-----------|
| 5290 | Antenna Cable - Ammeter End | .50 | .25 |
| 54102 | 3/8-32 x 1/2" Hex Nuts Cordanium | .25 | .25 |
| 57478 | Set Mounting Plate | .25 | .25 |
| 58-25 | Delco-Remy Fuse Bushing | .01 | .01 |
| 63-336 | 15 M. ohm Distributor Suppressor | .35 | .35 |
| 69-84 | No. 10/32 x 1/4" R.H.M.S. | .30 | .30 |
| 93-127 | No. 10 Mounting Strap | .35 | .35 |
| 93-143 | Lockwasher | .01 | .01 |
| 93-222 | 7/16" Internal Shakerproof | .01 | .01 |
| 93-233 | Lockwasher | .01 | .01 |
| 138-5 | 2 1/4" Dia. | .02 | .02 |
| 158-4 | 15 M. ohm Fuse | .02 | .02 |
| 183-2 | 7/16" x 3/8" Locking Bolt & Nut | .01 | .01 |
| 186-1 | Insulation Template | .01 | .01 |
| 186-1 | Mounting Plate Gasket | .03 | .03 |

| Part No. | Description | QTY | ST. PRICE |
|----------|----------------------------------|-----|-----------|
| 5290 | Antenna Cable - Ammeter End | .50 | .25 |
| 54102 | 3/8-32 x 1/2" Hex Nuts Cordanium | .25 | .25 |
| 57478 | Set Mounting Plate | .25 | .25 |
| 58-25 | Delco-Remy Fuse Bushing | .01 | .01 |
| 63-336 | 15 M. ohm Distributor Suppressor | .35 | .35 |
| 69-84 | No. 10/32 x 1/4" R.H.M.S. | .30 | .30 |
| 93-127 | No. 10 Mounting Strap | .35 | .35 |
| 93-143 | Lockwasher | .01 | .01 |
| 93-222 | 7/16" Internal Shakerproof | .01 | .01 |
| 93-233 | Lockwasher | .01 | .01 |
| 138-5 | 2 1/4" Dia. | .02 | .02 |
| 158-4 | 15 M. ohm Fuse | .02 | .02 |
| 183-2 | 7/16" x 3/8" Locking Bolt & Nut | .01 | .01 |
| 186-1 | Insulation Template | .01 | .01 |
| 186-1 | Mounting Plate Gasket | .03 | .03 |

| Part No. | Description | QTY | ST. PRICE |
|----------|----------------------------------|-----|-----------|
| 5290 | Antenna Cable - Ammeter End | .50 | .25 |
| 54102 | 3/8-32 x 1/2" Hex Nuts Cordanium | .25 | .25 |
| 57478 | Set Mounting Plate | .25 | .25 |
| 58-25 | Delco-Remy Fuse Bushing | .01 | .01 |
| 63-336 | 15 M. ohm Distributor Suppressor | .35 | .35 |
| 69-84 | No. 10/32 x 1/4" R.H.M.S. | .30 | .30 |
| 93-127 | No. 10 Mounting Strap | .35 | .35 |
| 93-143 | Lockwasher | .01 | .01 |
| 93-222 | 7/16" Internal Shakerproof | .01 | .01 |
| 93-233 | Lockwasher | .01 | .01 |
| 138-5 | 2 1/4" Dia. | .02 | .02 |
| 158-4 | 15 M. ohm Fuse | .02 | .02 |
| 183-2 | 7/16" x 3/8" Locking Bolt & Nut | .01 | .01 |
| 186-1 | Insulation Template | .01 | .01 |
| 186-1 | Mounting Plate Gasket | .03 | .03 |

| Part No. | Description | QTY | ST. PRICE |
|----------|----------------------------------|-----|-----------|
| 5290 | Antenna Cable - Ammeter End | .50 | .25 |
| 54102 | 3/8-32 x 1/2" Hex Nuts Cordanium | .25 | .25 |
| 57478 | Set Mounting Plate | .25 | .25 |
| 58-25 | Delco-Remy Fuse Bushing | .01 | .01 |
| 63-336 | 15 M. ohm Distributor Suppressor | .35 | .35 |
| 69-84 | No. 10/32 x 1/4" R.H.M.S. | .30 | .30 |
| 93-127 | No. 10 Mounting Strap | .35 | .35 |
| 93-143 | Lockwasher | .01 | .01 |
| 93-222 | 7/16" Internal Shakerproof | .01 | .01 |
| 93-233 | Lockwasher | .01 | .01 |
| 138-5 | 2 1/4" Dia. | .02 | .02 |
| 158-4 | 15 M. ohm Fuse | .02 | .02 |
| 183-2 | 7/16" x 3/8" Locking Bolt & Nut | .01 | .01 |
| 186-1 | Insulation Template | .01 | .01 |
| 186-1 | Mounting Plate Gasket | .03 | .03 |