

ZENITH RADIO CORP.

MODEL 4K640
 MODEL 5R680X
 MODEL 5G603
 MODELS 6G638, 6G660

Model 4K640 ALIGNMENT PROCEDURE Chassis No. 4B05

Operation	Conn. Test Osc. to	Dummy Ant.	Input Sig. Freq.	Band	Set Dial At	Trimmers	Purpose
1	Converter Grid	.5 Mfd.	455 Kc.	Broadcast	600 Kc.	A B C D	Align I. F.
2	Ant.—Gnd.	400 Ohms	18 Mc.	Short Wave	18 Mc.	K	Set Osc. to Scale
3	Ant.—Gnd.	200 Mmf.	1600 Kc.	Broadcast	1600 Kc.	F	Set Osc. to Scale
4	Ant.—Gnd.	200 Mmf.	1400 Kc.	Broadcast	1400 Kc.	G	Align Ant.
5	Ant.—Gnd.	200 Mmf.	600 Kc.	Broadcast	600 Kc.	J	Rock Gang & Adj. to Merc.
6	Ant.—Gnd.	400 Ohms	18 Mc.	Short Wave	18 Mc.	M	Rock Gang

Model 5G603

Operation	Connect Test Oscillator to	Dummy Antenna	Set Test Oscillator to	Band	Set Dial At	Adjust Trimmers	Purpose
1	Converter Grid	.5 mf.	455	—	600	A B C D	I. F. Alignment
2	Single Turn Loop Coupled Loosely to Wave Magnet	—	1400	—	1400	F	Set Osc. to Scale
3	Wave Magnet	—	1400	—	1400	G	Alignment of Antenna

Gnd. of test osc. connected to No. 8 pin of ILA6 socket.

Model 5R680X

Operation	Connect Oscillator to	Dummy Antenna	Input Signal Frequency	Band	Set Dial At	Trimmers	Purpose
1	Converter Grid	.5 mfd.	455 Kc.	BC	1600 Kc.	A, B, C, D	Align I.F.
2	Ant. & Grnd with 10 ohm shunt	.5 mfd.	1600 Kc.	"	1600 Kc.	F	Set to Scale
3	"	.5 mfd.	1400 Kc.	"	1400 Kc.	H, G	Align Ant.

Models 6G638—6G660 Chassis No. 6B09

Operation	Conn. Test Osc. to	Dummy Ant.	Input Sig. Freq.	Band	Set Dial At	Trimmers	Purpose
1	Converter Grid	.1 Mfd.	455 Kc.	B.C.	600 Kc.	A B C D	Align I.F.
2	Ant. & Grnd with 10 ohm shunt	400 Ohm	18 Mc.	S.W.	18 Mc.	K	Set to Scale
3	"	"	16 Mc.	S.W.	16 Mc.	M	Align Ant.
4	"	"	5 Mc.	Police	5 Mc.	N	Set to Scale
5	"	"	"	"	"	Q	Align Ant.
6	"	200 mmf	1800 Kc.	B.C.	1800 Kc.	F	Set to Scale
7	"	"	1700 Kc.	"	1700 Kc.	G—H	Align R.F. & det.
8	"	"	600 Kc.	"	600 Kc.	J	Rock gang & Adj. padder
9	"	"	1800 Kc.	"	1800 Kc.	F—G—H	Repeat 6 & 7

John F. Rider

MODELS 6G638, 6G660
Chassis 6B09

ZENITH RADIO CORP.

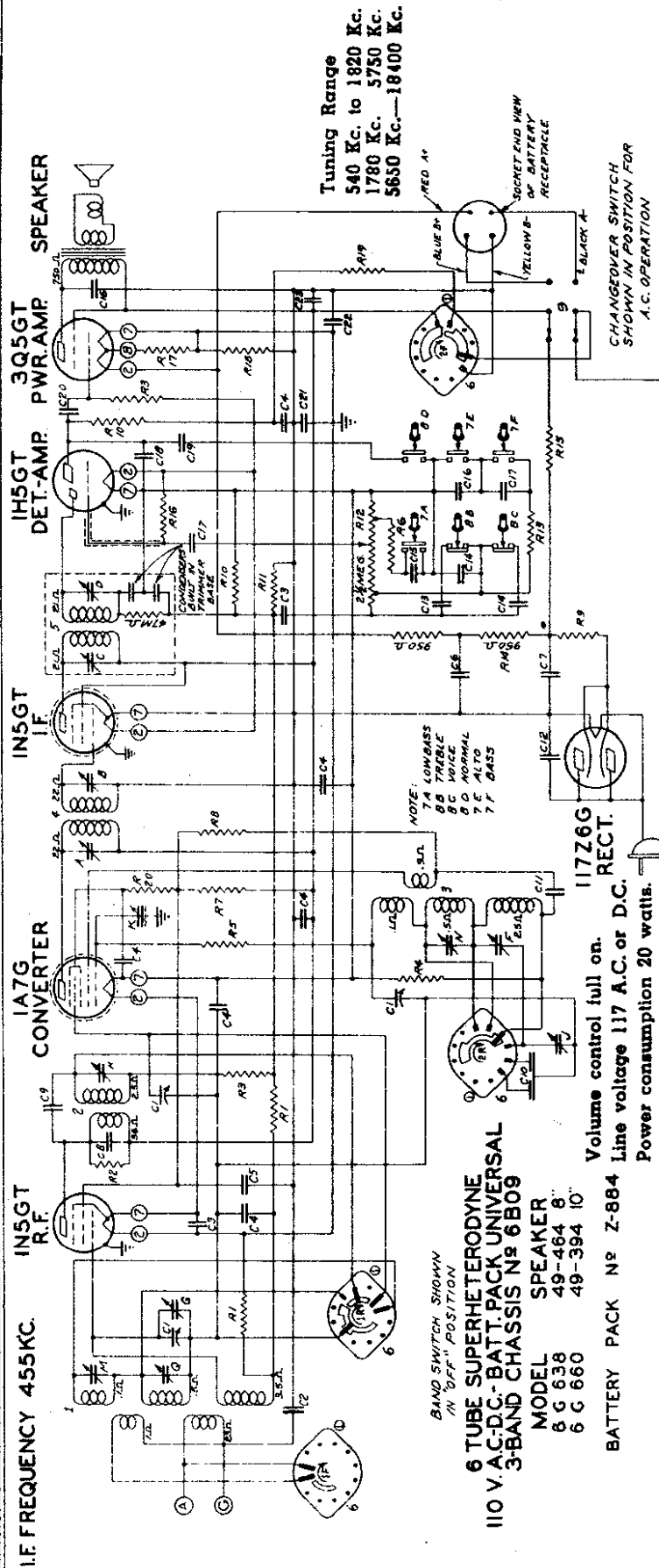

Tuning Range
540 Kc. to 1820 Kc.
1780 Kc. 5750 Kc.
5650 Kc. 18400 Kc.

FOR ALIGNMENT
SEE INDEX

CHANGEOVER SWITCH
SHOWN IN POSITION FOR
A.C. OPERATION

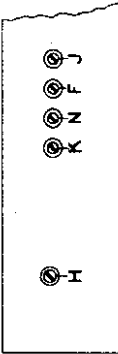

QWKS PART NO.	DESCRIPTION	QWKS PART NO.	DESCRIPTION	QWKS PART NO.	DESCRIPTION
C1	20-175 THREE GANG VARIABLE	R13	63-534 60M OHM	H	117Z6G RECTIFIER
C2	22-183 .01 MFD.	R14	63-1559 TWO-SECTION CHOKING	I	117Z6G VOLUME CONTROL
C3	22-185 .02 MFD.	R15	63-1559 1000 OHM	J	117Z6G BAND SWITCH
C4	22-185 .03 MFD.	R16	63-605 1000 OHM	K	117Z6G TUNING CONTROL
C5	22-185 .05 MFD.	R17	63-576 15 MEGOHM	L	117Z6G SPEAKER
C6	22-185 .10 MFD.	R18	63-576 15 MEGOHM	M	117Z6G ANTENNA COIL ASSEMBLY
C7	22-185 .20 MFD.	R19	63-576 15 MEGOHM	N	117Z6G DISCOILATOR COIL
C8	22-185 .50 MFD.	R20	63-576 15 MEGOHM	O	117Z6G I.F. TRANSFORMER
C9	22-185 1.0 MFD.	R21	63-576 15 MEGOHM	P	117Z6G TONE CONTROL SWITCH
C10	22-185 5.0 MFD.	R22	63-576 15 MEGOHM	Q	117Z6G TONE CONTROL (LEFT)
C11	22-185 10.0 MFD.	R23	63-576 15 MEGOHM	R	117Z6G TONE CONTROL (RIGHT)
C12	22-185 50.0 MFD.	R24	63-576 15 MEGOHM	S	117Z6G CHANGEOVER SWITCH
C13	22-185 100.0 MFD.	R25	63-576 15 MEGOHM	T	117Z6G ANTENNA COIL ASSEMBLY
C14	22-185 200.0 MFD.	R26	63-576 15 MEGOHM	U	117Z6G DISCOILATOR COIL
C15	22-185 500.0 MFD.	R27	63-576 15 MEGOHM	V	117Z6G I.F. TRANSFORMER
C16	22-185 1000.0 MFD.	R28	63-576 15 MEGOHM	W	117Z6G TONE CONTROL SWITCH
C17	22-185 2000.0 MFD.	R29	63-576 15 MEGOHM	X	117Z6G TONE CONTROL (LEFT)
C18	22-185 5000.0 MFD.	R30	63-576 15 MEGOHM	Y	117Z6G TONE CONTROL (RIGHT)
C19	22-185 10000.0 MFD.	R31	63-576 15 MEGOHM	Z	117Z6G CHANGEOVER SWITCH
C20	22-185 20000.0 MFD.	R32	63-576 15 MEGOHM	AA	117Z6G ANTENNA COIL ASSEMBLY
C21	22-185 50000.0 MFD.	R33	63-576 15 MEGOHM	AB	117Z6G DISCOILATOR COIL
C22	22-185 100000.0 MFD.	R34	63-576 15 MEGOHM	AC	117Z6G I.F. TRANSFORMER
C23	22-185 200000.0 MFD.	R35	63-576 15 MEGOHM	AD	117Z6G TONE CONTROL SWITCH
C24	22-185 500000.0 MFD.	R36	63-576 15 MEGOHM	AE	117Z6G TONE CONTROL (LEFT)
C25	22-185 1000000.0 MFD.	R37	63-576 15 MEGOHM	AF	117Z6G TONE CONTROL (RIGHT)
C26	22-185 2000000.0 MFD.	R38	63-576 15 MEGOHM	AG	117Z6G CHANGEOVER SWITCH
C27	22-185 5000000.0 MFD.	R39	63-576 15 MEGOHM	AH	117Z6G ANTENNA COIL ASSEMBLY
C28	22-185 10000000.0 MFD.	R40	63-576 15 MEGOHM	AI	117Z6G DISCOILATOR COIL
C29	22-185 20000000.0 MFD.	R41	63-576 15 MEGOHM	AJ	117Z6G I.F. TRANSFORMER
C30	22-185 50000000.0 MFD.	R42	63-576 15 MEGOHM	AK	117Z6G TONE CONTROL SWITCH
C31	22-185 100000000.0 MFD.	R43	63-576 15 MEGOHM	AL	117Z6G TONE CONTROL (LEFT)
C32	22-185 200000000.0 MFD.	R44	63-576 15 MEGOHM	AM	117Z6G TONE CONTROL (RIGHT)
C33	22-185 500000000.0 MFD.	R45	63-576 15 MEGOHM	AN	117Z6G CHANGEOVER SWITCH
C34	22-185 1000000000.0 MFD.	R46	63-576 15 MEGOHM	AO	117Z6G ANTENNA COIL ASSEMBLY
C35	22-185 2000000000.0 MFD.	R47	63-576 15 MEGOHM	AP	117Z6G DISCOILATOR COIL
C36	22-185 5000000000.0 MFD.	R48	63-576 15 MEGOHM	AQ	117Z6G I.F. TRANSFORMER
C37	22-185 10000000000.0 MFD.	R49	63-576 15 MEGOHM	AR	117Z6G TONE CONTROL SWITCH
C38	22-185 20000000000.0 MFD.	R50	63-576 15 MEGOHM	AS	117Z6G TONE CONTROL (LEFT)
C39	22-185 50000000000.0 MFD.	R51	63-576 15 MEGOHM	AT	117Z6G TONE CONTROL (RIGHT)
C40	22-185 100000000000.0 MFD.	R52	63-576 15 MEGOHM	AU	117Z6G CHANGEOVER SWITCH
C41	22-185 200000000000.0 MFD.	R53	63-576 15 MEGOHM	AV	117Z6G ANTENNA COIL ASSEMBLY
C42	22-185 500000000000.0 MFD.	R54	63-576 15 MEGOHM	AW	117Z6G DISCOILATOR COIL
C43	22-185 1000000000000.0 MFD.	R55	63-576 15 MEGOHM	AX	117Z6G I.F. TRANSFORMER
C44	22-185 2000000000000.0 MFD.	R56	63-576 15 MEGOHM	AY	117Z6G TONE CONTROL SWITCH
C45	22-185 5000000000000.0 MFD.	R57	63-576 15 MEGOHM	AZ	117Z6G TONE CONTROL (LEFT)
C46	22-185 10000000000000.0 MFD.	R58	63-576 15 MEGOHM	BA	117Z6G TONE CONTROL (RIGHT)
C47	22-185 20000000000000.0 MFD.	R59	63-576 15 MEGOHM	BB	117Z6G CHANGEOVER SWITCH
C48	22-185 50000000000000.0 MFD.	R60	63-576 15 MEGOHM	BC	117Z6G ANTENNA COIL ASSEMBLY
C49	22-185 100000000000000.0 MFD.	R61	63-576 15 MEGOHM	BD	117Z6G DISCOILATOR COIL
C50	22-185 200000000000000.0 MFD.	R62	63-576 15 MEGOHM	BE	117Z6G I.F. TRANSFORMER
C51	22-185 500000000000000.0 MFD.	R63	63-576 15 MEGOHM	BF	117Z6G TONE CONTROL SWITCH
C52	22-185 1000000000000000.0 MFD.	R64	63-576 15 MEGOHM	BG	117Z6G TONE CONTROL (LEFT)
C53	22-185 2000000000000000.0 MFD.	R65	63-576 15 MEGOHM	BH	117Z6G TONE CONTROL (RIGHT)
C54	22-185 5000000000000000.0 MFD.	R66	63-576 15 MEGOHM	BI	117Z6G CHANGEOVER SWITCH
C55	22-185 10000000000000000.0 MFD.	R67	63-576 15 MEGOHM	BJ	117Z6G ANTENNA COIL ASSEMBLY
C56	22-185 20000000000000000.0 MFD.	R68	63-576 15 MEGOHM	BK	117Z6G DISCOILATOR COIL
C57	22-185 50000000000000000.0 MFD.	R69	63-576 15 MEGOHM	BL	117Z6G I.F. TRANSFORMER
C58	22-185 100000000000000000.0 MFD.	R70	63-576 15 MEGOHM	BM	117Z6G TONE CONTROL SWITCH
C59	22-185 200000000000000000.0 MFD.	R71	63-576 15 MEGOHM	BN	117Z6G TONE CONTROL (LEFT)
C60	22-185 500000000000000000.0 MFD.	R72	63-576 15 MEGOHM	BO	117Z6G TONE CONTROL (RIGHT)
C61	22-185 1000000000000000000.0 MFD.	R73	63-576 15 MEGOHM	BP	117Z6G CHANGEOVER SWITCH
C62	22-185 2000000000000000000.0 MFD.	R74	63-576 15 MEGOHM	BQ	117Z6G ANTENNA COIL ASSEMBLY
C63	22-185 5000000000000000000.0 MFD.	R75	63-576 15 MEGOHM	BR	117Z6G DISCOILATOR COIL
C64	22-185 10000000000000000000.0 MFD.	R76	63-576 15 MEGOHM	BS	117Z6G I.F. TRANSFORMER
C65	22-185 20000000000000000000.0 MFD.	R77	63-576 15 MEGOHM	BT	117Z6G TONE CONTROL SWITCH
C66	22-185 50000000000000000000.0 MFD.	R78	63-576 15 MEGOHM	BU	117Z6G TONE CONTROL (LEFT)
C67	22-185 100000000000000000000.0 MFD.	R79	63-576 15 MEGOHM	BV	117Z6G TONE CONTROL (RIGHT)
C68	22-185 200000000000000000000.0 MFD.	R80	63-576 15 MEGOHM	BW	117Z6G CHANGEOVER SWITCH
C69	22-185 500000000000000000000.0 MFD.	R81	63-576 15 MEGOHM	BX	117Z6G ANTENNA COIL ASSEMBLY
C70	22-185 1000000000000000000000.0 MFD.	R82	63-576 15 MEGOHM	BY	117Z6G DISCOILATOR COIL
C71	22-185 2000000000000000000000.0 MFD.	R83	63-576 15 MEGOHM	BZ	117Z6G I.F. TRANSFORMER
C72	22-185 5000000000000000000000.0 MFD.	R84	63-576 15 MEGOHM	CA	117Z6G TONE CONTROL SWITCH
C73	22-185 10000000000000000000000.0 MFD.	R85	63-576 15 MEGOHM	CB	117Z6G TONE CONTROL (LEFT)
C74	22-185 20000000000000000000000.0 MFD.	R86	63-576 15 MEGOHM	CC	117Z6G TONE CONTROL (RIGHT)
C75	22-185 50000000000000000000000.0 MFD.	R87	63-576 15 MEGOHM	CD	117Z6G CHANGEOVER SWITCH
C76	22-185 100000000000000000000000.0 MFD.	R88	63-576 15 MEGOHM	CE	117Z6G ANTENNA COIL ASSEMBLY
C77	22-185 200000000000000000000000.0 MFD.	R89	63-576 15 MEGOHM	CF	117Z6G DISCOILATOR COIL
C78	22-185 500000000000000000000000.0 MFD.	R90	63-576 15 MEGOHM	CG	117Z6G I.F. TRANSFORMER
C79	22-185 1000000000000000000000000.0 MFD.	R91	63-576 15 MEGOHM	CH	117Z6G TONE CONTROL SWITCH
C80	22-185 2000000000000000000000000.0 MFD.	R92	63-576 15 MEGOHM	CI	117Z6G TONE CONTROL (LEFT)
C81	22-185 5000000000000000000000000.0 MFD.	R93	63-576 15 MEGOHM	CK	117Z6G TONE CONTROL (RIGHT)
C82	22-185 10000000000000000000000000.0 MFD.	R94	63-576 15 MEGOHM	CL	117Z6G CHANGEOVER SWITCH
C83	22-185 20000000000000000000000000.0 MFD.	R95	63-576 15 MEGOHM	CM	117Z6G ANTENNA COIL ASSEMBLY
C84	22-185 50000000000000000000000000.0 MFD.	R96	63-576 15 MEGOHM	CN	117Z6G DISCOILATOR COIL
C85	22-185 100000000000000000000000000.0 MFD.	R97	63-576 15 MEGOHM	CO	117Z6G I.F. TRANSFORMER
C86	22-185 200000000000000000000000000.0 MFD.	R98	63-576 15 MEGOHM	CP	117Z6G TONE CONTROL SWITCH
C87	22-185 500000000000000000000000000.0 MFD.	R99	63-576 15 MEGOHM	CQ	117Z6G TONE CONTROL (LEFT)
C88	22-185 1000000000000000000000000000.0 MFD.	R100	63-576 15 MEGOHM	CR	117Z6G TONE CONTROL (RIGHT)
C89	22-185 2000000000000000000000000000.0 MFD.	R101	63-576 15 MEGOHM	CS	117Z6G CHANGEOVER SWITCH
C90	22-185 5000000000000000000000000000.0 MFD.	R102	63-576 15 MEGOHM	CT	117Z6G ANTENNA COIL ASSEMBLY
C91	22-185 10000000000000000000000000000.0 MFD.	R103	63-576 15 MEGOHM	CU	117Z6G DISCOILATOR COIL
C92	22-185 20000000000000000000000000000.0 MFD.	R104	63-576 15 MEGOHM	CV	117Z6G I.F. TRANSFORMER
C93	22-185 50000000000000000000000000000.0 MFD.	R105	63-576 15 MEGOHM	CW	117Z6G TONE CONTROL SWITCH
C94	22-185 100000000000000000000000000000.0 MFD.	R106	63-576 15 MEGOHM	CX	117Z6G TONE CONTROL (LEFT)
C95	22-185 200000000000000000000000000000.0 MFD.	R107	63-576 15 MEGOHM	CY	117Z6G TONE CONTROL (RIGHT)
C96	22-185 500000000000000000000000000000.0 MFD.	R108	63-576 15 MEGOHM	CZ	117Z6G CHANGEOVER SWITCH
C97	22-185 1000000000000000000000000000000.0 MFD.	R109	63-576 15 MEGOHM	DA	117Z6G ANTENNA COIL ASSEMBLY
C98	22-185 2000000000000000000000000000000.0 MFD.	R110	63-576 15 MEGOHM	DB	117Z6G DISCOILATOR COIL
C99	22-185 5000000000000000000000000000000.0 MFD.	R111	63-576 15 MEGOHM	DC	117Z6G I.F. TRANSFORMER
C100	22-185 10000000000000000000000000000000.0 MFD.	R112	63-576 15 MEGOHM	DD	117Z6G TONE CONTROL SWITCH

Stage Gains
Pc. and I.F.

Ant. to R.F. grid 6.8 X at 1000 Kc.
R.F. grid to conv. grid 3.8 X at 1000 Kc.
Conv. grid to I.F. grid 66 X at 455 Kc.
Overall audio 425 X at .05 watt.
400 cycles.

